

# ES-H/HA PRECISION BALANCES



ES-H with Aluminum Base



ES-HA with ABS Plastic Base

## Features

- **Applications:** Laboratory, Jewelry, Gold stores, Hospital, Chemistry, School teaching
- **Loadcell:** High precision single point alum. loadcell, resolution up to 1/80000
- **Construction:** ES-H: Cast Aluminum base  
EH-HA: ABS plastic base  
Stainless steel platter in round or square shape  
Glass or plastic wind shield offers more accurate reading  
Leveling bubble and adjustable feet for quick set-up and stability
- **Indicator:** Large and easy-to-read backlit LCD display  
6 keys: ON/OFF, Count, Cal, Tare, Mode, Unit
- **Functions:** One-step "CAL" key for fast calibration  
Weighing, Parts counting function  
Overload indication, Low battery indication, Auto-off function

## Specifications

Item	Parameters					
ES-H Capacity	300gx0.01g	500gx0.01g	600gx0.01g	1200gx0.01g	3000gx0.1g	8000gx0.1g
ES-HA Capacity	200gx0.001g	300gx0.001g	300gx0.01g	500gx0.01g	600gx0.01g	1200gx0.01g
Units of Measure	g, oz, ozt, dwt, ct, lb, t, pcs					
Display	6 ½ digits, 0.75"(19mm) high, 7 segments backlit LCD display					
Power	6V 200mA AC adapter or 8xAA batteries (ES-H) / 6xAA batteries (ES-HA)					
Serial Port	RS232					
Operation Temp	10°C to 35°C (50°F to 95°F)					
Platter Size	200g-1000g: φ 118mm (4.6") round pan 1000g-8000g: 175x175mm / 6.875"x6.875" square pan					
Packing	655x530x445mm/12pcs/ctn		G.W.: 22kg N.W.: 20kg			
Approvals	CE and WEEE directive, UL/CE/BS approved power adapter					
Options	Wind shield, RS232 cable					

## Dimensions (mm/inch)

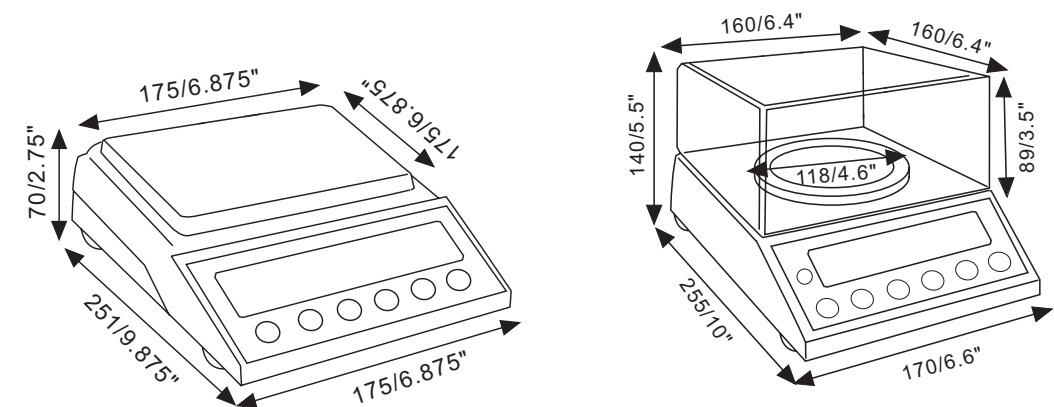

- Easy-to-read backlit LCD display
- 6 operation keys access functions of weighing, tare, unit switching, parts counting and percentage weighing



- Plastic or glass wind shield for choose, to ensure more accurate weighing



- Standard RS232 serial port, allows to communicate with computer